

# eGATE SMART BUILDING INNOVATION

**eGate**  
Smart Building Innovation

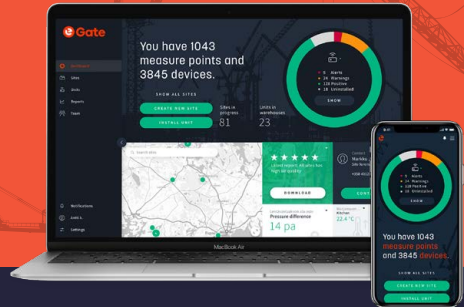

eGate's real-time IoT sensor data enables maximizing the project profitability through better scheduling and helps monitoring job site environment for health and safety.

## eGate Overview

**eGate** is a cloud-connected IoT solution for remote monitoring of construction job sites. It has the widest range of high-precision IoT sensors on the market. All sensors are connected directly to the eGate cloud data platform with visual floor plans and mobile access.

### What eGate does at the job site:

- Concrete RH+ Temp measurement for flooring projects with industry leading 1% accuracy
- ASTM 2170 compliant concrete sensors for RH + Temp + Strength
- Concrete temperature measurement for calculating concrete strength using ASTM or Sadgrove conversion curves
- ePredict prediction algorithms for forecasting the drying time for concrete floor slab
- ePredict algorithms to monitor the concrete strength development
- Silica dust monitoring at the job site, with 8h average reporting vs. OSHA limits
- Air particle monitoring for both hazardous dust and normal construction dust for cleanliness, for managing the cleaning processes
- Monitoring ambient air for optimal conditions for RH+Temp, Differential Pressure, CO<sub>2</sub>, TVOC,...
- Project reports in PDF and excel format, with time stamps and location data with visual floor plans
- Real-time cloud data, with online dashboard and access with all devices, mobile and desktop
- Live mobile alerts for values that exceed the set min/max thresholds

## eGATE DUST40, DUST13, KOMBI-DB, RHT-in and RHT-out

The eGate-Kombi-LWUS is an economical multi-sensor indoor air quality (IAQ) transmitter series. Depending on the variant, eGate-Kombi-LWUS can measure temperature, humidity, differential pressure, and particulate matter (PM). eGate-Kombi-LWUS uses LoRaWAN for communication with the cloud data collection system.

### Mounting, except for RHT-out

Select the installation location so that air can flow freely on all sides of the transmitter, representing the air that is to be measured. Avoid heat sources and direct sunlight. Mount the device to the measuring location with one of the following ways:

- Simply place the Kombi-LWUS on any surface with the bottom facing down.
- First mount the separate wall holder with two universal countersunk screws (ST 2.5 or ST 3.0). Use applicable length and type of screws depending on wall material. In the correct orientation, the wall holder has its hooks pointing upwards. Attach the Kombi-LWUS to the holder.

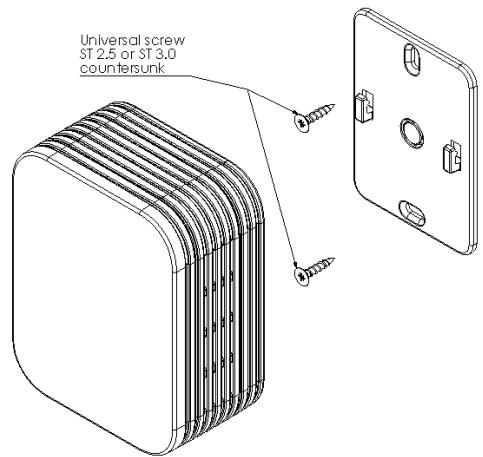

### Mounting RHT-out

This model can be mounted using any of the mounting screw holes in the fixed mounting flanges of the enclosure. Always make sure to mount the device in vertical orientation so that the ventilation holes in the bottom of the enclosure point downwards ensuring that water or any other liquids cannot enter through the ventilation holes. Ingress protection class IP42 can only be attained in the correct vertical mounting orientation.

## Mounting KOMBI-DP

Mount as instructed above and then attach the pressure hoses to the two black hose connectors at the bottom of the device. The device measures the pressure difference between the two hose connector ports. Use only flexible plastic hose with inner diameter of 4 mm / 0.15 in. When routing and installing the hose, make sure the hose does not get pinched or blocked. Always minimize the length of the pressure hoses. The maximum recommended pressure hose length is 1 m / 1.09 yd to attain the specified measuring accuracy.

The other hose connector port can and typically will be left without a hose connected to it.

## Easy Installation:

1. Log in at: [app.e-gate.io](https://app.e-gate.io)
2. Make sure the job site floor plan drawings have been uploaded to the eGate cloud.
3. Plan the location of measurement points.
4. Install the Sensors.
5. Start monitoring data & alerts.



[Watch video](#)

Ask your dealer for training on using the eGate system.  
Contact information: [www.e-gate.io/en/contact](https://www.e-gate.io/en/contact)

## FCC labels

FCC ID: 2A3B4KOMBI1

This equipment has been tested and found to comply with the limits for a Class B digital device, pursuant to part 15 of the FCC Rules. These limits are designed to provide reasonable protection against harmful interference in a residential installation. This equipment generates, uses and can radiate radio frequency energy and, if not installed and used in accordance with the instructions, may cause harmful interference to radio communications. However, there is no guarantee that interference will not occur in a particular installation. If this equipment does cause harmful interference to radio or television reception, which can be determined by turning the equipment off and on, the user is encouraged to try to correct the interference by one or more of the following measures:

- Reorient or relocate the receiving antenna.
- Increase the separation between the equipment and receiver.
- Connect the equipment into an outlet on a circuit different from that to which the receiver is connected.
- Consult the dealer or an experienced radio/TV technician for help.

### FCC CAUTION

Changes or modifications not expressly approved by the party responsible for compliance could void the user's authority to operate the equipment.

This transmitter must not be co-located or operated in conjunction with any other antenna or transmitter.

This equipment complies with FCC/IC radiation exposure limits set forth for an uncontrolled environment and meets the FCC radio frequency (RF) Exposure Guidelines and RSS-102 of the IC radio frequency (RF) Exposure rules. This equipment should be installed and operated keeping the radiator at least 20cm or more away from person's body.